

KERALA STATE ELECTRICITY REGULATORY COMMISSION

Dated 24th January 2014

NOTICE

Notice is hereby given that Kerala State Electricity Regulatory Commission has published the Draft Kerala State Electricity Regulatory Commission (Grid Interactive Distributed Solar Energy Systems) Regulations, 2014. Stake holders including public are requested to forward their comments/ responses on the draft regulations, to the Commission on or before 28-02-2014. The stake holders and the public can present their responses/comments on the draft regulation in the public hearing also which shall be held at 11 AM on 19.03.2014 at the Office of the Commission. The Draft Kerala State Electricity Regulatory Commission (Grid Interactive Distributed Solar Energy Systems) Regulations, 2014 is available in the web site of the Commission www.erckerala.org.

Sd/-

Secretary

(Draft for publication)

KERALA STATE ELECTRICITY REGULATORY COMMISSION

Notification

No. KSERC/CT/

Dated. 24.01.2014

Kerala State Electricity Regulatory Commission (Grid Interactive Distributed Solar Energy Systems) Regulations, 2014

In exercise of powers conferred under sections 61, 66, 86 (1) (e) and 181 of the Electricity Act, 2003 (Act 36 of 2003) and all other powers enabling it in this behalf, and after previous publication, the Kerala State Electricity Regulatory Commission hereby makes the following regulations for the grid interactive distributed solar energy system:

1. Short title, extent and commencement.- (1) These regulations may be called the Kerala State Electricity Regulatory Commission **(Grid Interactive Distributed Solar Energy Systems) Regulations, 2014.**

(2) These Regulations shall apply to all the distribution licensees and the consumers of electricity in the State of Kerala.

(3) These regulations shall come into force from the date of notification in the Official Gazette

2. Definitions.- In these regulations, unless the context otherwise requires,

- (1) **“Act”** means the Electricity Act, 2003 (Central Act 36 of 2003) as amended from time to time;
- (2) **“agreement”** means an agreement entered into between the distribution licensee and the consumer;
- (3) **“application form”** means an application form complete in all respects in the appropriate format, as required by the distribution licensee, before the payment of applicable charges;
- (4) **“application”** means an application form complete in all respects in the appropriate format, as required by the distribution licensee, along with the receipt for payment of necessary charges and all necessary documents including approvals from statutory or other authorities;

- (5) **“billing cycle or billing period”** means the period as approved by the Commission for which regular electricity bills are prepared by the licensee for different categories of consumers;
- (6) **“Commission”** means the Kerala State Electricity Regulatory Commission constituted under the Act;
- (7) **“consumer”** means any person who is supplied with electricity for his own use by a licensee or the Government or by any other person engaged in the business of supplying electricity to the public under this Act or any other law for the time being in force and includes any person whose premises are, for the time being, connected for the purpose of receiving electricity with the works of a distribution licensee, the Government or such other person, as the case may be;
- (8) **“contracted connected load”** means the connected load installed by the consumer at the time of executing the service connection agreement and recorded in kW / kVA in the schedule to the said agreement or the connected load duly revised thereafter;
- (9) **“contracted load”** or **“contract demand”** means the maximum demand in kW or kVA, agreed to be supplied by the distribution licensee and indicated in the agreement executed between the licensee and the consumer; or the contracted load or contract demand duly revised thereafter;
- (10) **“distribution licensee”** or **“licensee”** means a person granted licence under Section 14 of the Act authorizing him to operate and maintain a distribution system and to supply electricity to the consumers in his area of supply, and includes a deemed licensee;
- (11) **“eligible consumer”** means a consumer of electricity in the area of supply of the distribution licensee, who uses a grid interactive distributed solar energy system whether owned by himself or by a third party, installed in the consumer premises, to meet all or part of the energy requirement of the consumer;
- (12) **“financial year”** means the period beginning from the first of April in a Gregorian calendar year and ending with the thirty first of March of the next year;
- (13) **“grid interactive distributed solar energy system”** means the solar photo voltaic power system installed in the premises of consumer;
- (14) **“interconnection point”** means the point of interconnection between the grid interactive distributed solar energy system installed or proposed to be installed by the consumer and the distribution system of the licensee;
- (15) **“invoice”** means either a Bill / Supplementary Bill or a Invoice / Supplementary Invoice related to the billing cycle or billing period raised by the distribution licensee;
- (16) **“kWp”** means kilo Watt peak;

- (17) **“net meter”** means the bi-directional energy meter for measuring the quanta of electricity flowing in opposite directions and the net quantum of electricity consumed by the consumer or injected into the distribution system of the licensee; which shall be an integral part of the net metering system.
- (18) **“net metering system”** means a system consisting of a solar meter to measure the quantum of electricity generated and injected into the installation of the consumer or into the distribution system of the licensee, by a grid interactive distributed solar energy system and a net meter to measure the quanta of electricity flowing in opposite directions as well as the net quantum of electricity drawn by the consumer or injected into the distribution system of the licensee as per Annexure 1;
- (19) **“normal period”** means the period from 6.00 hours to 18.00 hours on the same day;
- (20) **“obligated entity”** means the entity mandated to fulfill the renewable purchase obligation under KSERC (Renewable Purchase Obligation and Its Compliance) Regulations, 2010 as amended from time to time;
- (21) **“off-peak period”** means 22.00 hours to 6.00 hours on the next day;
- (22) **“peak-hours”** means 18.00 hours to 22.00 hours on the same day;
- (23) **“premises”** includes any land or building or structure which is included in the details and sketches specified in the application or in the agreement for grant of electric connection or in such other records relating to revision of connected load or contract demand;
- (24) **“Renewable Energy Certificate (REC)”** means the certificate issued in accordance with the provisions of the Central Electricity Regulatory Commission (Terms and Conditions for Recognition and Issue of Renewable Energy Certificate for Renewable Energy Generation) Regulations, 2010 as amended from time to time;
- (25) **“settlement period”** means the period beginning from first day of October in a Gregorian Calendar and ending with thirtieth day of September in the next year;
- (26) **“solar energy system”** means the grid interactive distributed solar energy system installed or proposed to be installed in the premises of any consumer;
- (27) **“solar meter”** means a unidirectional energy meter provided at the delivery point of the Grid Interactive Distributed Solar Energy System to the main panel of the eligible consumer, which shall be an integral part of the net metering system.
- (28) **“Supply Code”** means the Kerala Electricity Supply Code, 2014 specified under section 50 of the Act, as amended from time to time;
- (29) **“tariff order”** in respect of a licensee means the order issued from time to time by the Commission, stipulating the rates to be charged by the said licensee from various categories of consumers for supply of electrical energy and for other services.

3. Interpretations.- (1) This Code shall be interpreted and implemented in accordance with, and not at variance from, the provisions of the Act and the Rules and Regulations made thereunder.

(2) Words, terms and expressions defined in the Electricity Act, 2003, in the Rules made thereunder by the Central Government and Kerala State Government and in the Regulations issued by the Central Electricity Authority, the Central Electricity Regulatory Commission and the Commission and used in this Code shall have and carry the same meanings as defined and assigned in the said Act, Rules and Regulations.

(3) In the interpretation of this code, unless the context otherwise requires:-

(a) Words in the singular or plural term, as the case may be, shall also be deemed to include the plural or the singular term, respectively;

(b) References to any statutes, regulations or guidelines shall be construed as including all statutory provisions consolidating, amending or replacing such statutes, regulations or guidelines referred to, as the case may be;

(c) Terms “include” and “including” shall be deemed to be followed by “without limitation” or “but not limited to”, regardless of whether such terms are followed by such phrases or words of like import.

4. Eligibility and general conditions of installation of grid interactive distributed solar energy system.- (1) All consumers in the area of supply of the distribution licensee are eligible to install in their premises, the grid interactive distributed solar energy system, either owned by them or by any third party.

(2) The solar energy system installed by the consumer shall be:

(a) within the permissible rated capacity as specified under these Regulations.

(b) located in the premises of the consumer.

(c) Interconnected with interlocking system and operated safely in parallel with the distribution system of the licensee.

(3) The capacity of the solar energy system to be installed at the premises of any consumer shall not exceed three megawatt (MW):

Provided that the capacity of the solar energy system shall be in conformity with the provisions relating to the connected load or contract demand permissible at each voltage level as specified in the Kerala Electricity Supply Code, 2014, as amended from time to time.

5. Obligation of the distribution licensee to make available the connectivity to its distribution system.- (1) The distribution licensee shall, without any discrimination, provide the connectivity to its distribution system for the solar energy system of every consumer in its area of supply,

(2) The connectivity shall be given in the order of the date of receipt of application from the consumer.

(3) The distribution licensee shall give connectivity to the solar energy system of any consumer provided the cumulative capacity of solar energy systems connected to the distribution system under a particular distribution transformer does not exceed fifty percent of the capacity of the such transformer.

Provided that the distribution licensee shall make available on its website and in its local offices, the information relating to the capacity available for connecting the solar energy systems to the distribution transformer and shall update such information.

(4) If the cumulative capacity of the solar energy systems under a distribution transformer exceeds the limit as provided in sub regulation (3) above, the licensee shall, within a period of two months, replace such transformer with another transformer of required higher capacity.

6. Obligation of the distribution licensee to provide banking facility and capacity target.- The obligation of the distribution licensee to provide banking facility to the eligible consumers shall be limited to the target capacity of the solar energy purchase obligation of the licensee, fixed by the Commission in accordance with the relevant provisions of the Kerala State Electricity Regulatory Commission (Renewable Purchase Obligation and its Compliance), Regulation, 2010, as amended from time to time:

Provided that the target capacity of solar energy purchase obligation of the licensee in megawatt or in kilowatt shall be assessed taking into account the renewable purchase obligation of the licensee and the capacity utilization factor of the solar energy system.

7. Specifications, standards and safety.- (1) The interconnection of the solar energy system with the distribution system of the licensee shall conform to the specifications and standards as provided in the Central Electricity Authority (Technical Standards for connectivity of the Distributed Generation Resources) Regulations, 2013, as amended from time to time.

(2) The interconnection of the solar energy system with the distribution system of the licensee shall conform to the relevant provisions of the Central Electricity Authority (Measures relating to Safety and Electric Supply), Regulations, 2010, as amended from time to time.

(3) The net meter and solar meter shall conform to the standards, specifications and accuracy class as provided in Central Electricity Authority (Installation and Operation of Meters) Regulations, 2006 as amended from time to time and shall be installed in such a way that they are accessible for reading.

8. Metering arrangement.- (1) Net meter shall be installed at the interconnection points of the eligible consumers with the network of the distribution licensee.

(2) Solar meter shall be installed at the delivery point of the solar energy system to measure the total solar electricity generated.

(3) The solar meter and net meter shall be compatible with meter reading instrument (MRI) or with wireless equipment for recording meter readings:

(4) Check meter shall be installed for the solar energy system having capacity more than 20kW and for the solar energy system of capacity less than or equal to 20 kW, the check meter would be optional:

(5) The meters installed shall be jointly inspected and sealed on behalf of both the parties and shall be tested and installed only in the presence of the representatives of the consumer and the distribution licensee:

(6) The meter reading taken by the distribution licensee shall form the basis of commercial settlement and a copy of the meter reading statement of the net meter and solar meter shall be handed over to the consumer as soon as meter reading is taken.

9. Obligation of the licensee to provide net metering system.- (1) The distribution licensee shall make available a correct net metering system to the consumer who proposes to install a solar energy system in his premises.

Provided that the consumer shall have the option to purchase the net metering system as provided in the Act and in the Central Electricity Authority (Installation and Operation of Meters) Regulations, 2006, as amended from time to time.

(2) The licensee may collect, at the rates specified by the Commission, the security deposit and meter rent for the net metering system provided by it to the consumer.

10. Obligation of the eligible consumer to provide safeguards to prevent injecting of energy to the de-energized distribution system.- The eligible consumer shall install inverter and associated equipment with sufficient safeguards to prevent injection of energy from his solar energy system to the distribution system of the licensee when it is de-energized.

11. Banking of electricity.- (1) The licensee shall allow to the eligible consumer, the banking facility for the electricity generated and injected into the distribution system by the solar energy system of the consumer, subject to the conditions specified in the subregulations below.

(2) The eligible consumer in time of the day (ToD) billing system shall be entitled to use the quantum of electricity banked by him, first in the corresponding normal period

in which the electricity was generated and injected into the system and the balance in the peak period and in the off peak period in succession.

(3) The eligible consumer who is not in time of the day (ToD) billing system shall be entitled to use the quantum of electricity banked by him, irrespective of the normal, peak or off-peak periods.

(4) The energy banked by an eligible consumer shall be accounted and settled in accordance with the provisions in regulations 15 and 16.

12. Right of the eligible consumer to use the excess energy in other premises.- (1)

The eligible consumer shall have the right to avail open access for wheeling the excess energy generated by the solar energy system installed in one of his premises and to use such excess energy in any other premises owned by him within the area of supply of the licensee.

(2) The eligible consumer shall apply to the licensee for availing the facility as per subregulation (1) above, with necessary particulars of all such other premises where such excess energy generated by the solar energy system installed in one of his premises, is proposed to be used.

(3) The licensee shall after due verification of the application submitted under subregulation (2) above and after satisfying about its genuineness, grant the facility to use the excess energy in such other premises owned by the eligible consumer.

(4) The modifications if any, required in the metering system in such other premises of the eligible consumer where the excess energy is proposed to be used, shall be made by the eligible consumer at his cost under the supervision of the licensee.

(5) The eligible consumer shall pay wheeling charges at the rate of five percent of the energy wheeled for use in other premises owned by him.

13. Application and its processing.- (1) Application form for the installation of the solar energy system and for its connectivity to the distribution system of the licensee shall be submitted along with the proof of ownership and proof of address as specified in the Kerala Electricity Supply Code, 2014, in the format specified in Annexure 2.

(2) The application form shall be submitted to the officer in charge of the local office of the licensee, along with the application fee and processing fee as specified in the schedule to these regulations.

(3) The licensee shall maintain a register for the applications received for the installation of grid interactive distributed solar energy system.

(4) The application shall be processed in the order of its receipt.

(5) On receipt of the application form, the officer in charge of the local office of the licensee shall inspect the premises of the consumer within three days from the date of receipt of such application form and verify the technical feasibility of providing connectivity to the distribution system of the licensee, considering the capacity of the distribution transformer under which such connectivity has to be provided.

(6) After inspection, the officer in charge of the local office of the licensee, shall issue within three working days, a demand note for remittance of security deposit for the metering system if the consumer has opted to avail the net metering system supplied by the licensee.

(7) On remittance of such security deposit for metering system, the licensee shall provide the net metering system and connectivity to the consumer within the period specified in regulation 13.

14. Time limits.- The connectivity to the distribution system of the licensee shall be granted within the following time limits:

No	Particulars	Time limits
1	If there is sufficient capacity in the nearest available distribution transformer	Within seven days from the receipt of application
2	If there is no sufficient capacity in the nearest available distribution transformer	Two months

Provided that the date of receipt of security deposit for metering system shall be deemed to be the date of receipt of application.

15. Accounting and settlement of electricity generated and consumed by an eligible consumer who is not in the ToD billing system.-(1) The total electricity generated and injected into the installation of the consumer and the distribution system during a billing period shall be assessed using the readings in the solar meter.

(2) The quantum of electricity drawn from the distribution system of the licensee for the use of eligible consumer, the quantum of electricity injected into the distribution system of the licensee and the net quantum of electricity used or injected into the distribution system by the eligible consumer during a billing period shall be assessed using the readings in net meter.

(3) The total electricity consumed by the eligible consumer shall be computed using the above readings.

(4) If the electricity generated and injected into the system as measured in the solar meter exceeds the total electricity consumed by the eligible consumer in the same premises during any billing period, such excess electricity injected into the distribution system may be used by him in any other premises owned by him as specified in regulation 12 above and balance excess electricity shall be carried forward to the next

billing period as electricity credit and shall be accounted and used to settle the electricity consumed by him in future billing periods.

(5) If the electricity generated and injected into the system by the eligible consumer as measured in the solar meter, is less than the total electricity consumed by him in all the premises owned by him within the area of supply of the licensee, during any billing period, the licensee shall recover from such eligible consumer, the electricity charges at the rates specified in tariff order issued by the Commission, for the net quantum of electricity drawn by him from the distribution system, after taking into account any electricity credit balance remaining from previous billing periods.

(6) The licensee shall give a statement of accounts of electricity showing the following particulars, along with the energy bill relating to each billing period:

- (i) quantum of electricity injected into the distribution system by the eligible consumer;
- (ii) quantum of electricity supplied by distribution licensee to the eligible consumer;
- (iii) quantum of net electricity which has been billed for payment by the consumer;
- (iv) quantum of electricity generated and injected into the distribution system in excess of the consumption by the eligible consumer which is carried over to the next billing period:

(7) The licensee shall pay for the net excess electricity injected into the distribution system from the solar energy system of an eligible consumer at the end of the settlement period at the average pooled purchase cost of electricity for the year.

16. Accounting and settlement of electricity generated and consumed by an eligible consumer who is in the ToD billing system.- (1) The total electricity generated and fed into the installation of the consumer and the distribution system during a billing period shall be assessed using the readings in the solar meter.

(2) The quantum of electricity drawn from the distribution system of the licensee for the use of eligible consumer, the quantum of electricity injected into the distribution system of the licensee and the net quantum of electricity used or injected into the distribution system by the eligible consumer during a billing period shall be assessed using the readings in net meter.

(3) The total electricity consumed by the eligible consumer shall be computed using the above readings.

(4) If the quantum of electricity generated and injected into the system by the solar energy system of the eligible consumer as measured in the solar meter, exceeds the total electricity consumed during the normal period in all the premises owned by him, within the area of supply of the licensee, in any billing period, such excess electricity

injected into the distribution system shall be set off, first against the electricity used during the peak period and then during the off peak period in the same billing period.

(5) If the quantum of electricity generated and injected into the distribution system by the solar energy system of the eligible consumer during a billing period exceeds the quantum of electricity consumed by him during the same billing period and adjusted as per sub-regulation (4) above, such excess electricity shall be carried forward to the next billing period as electricity credit and shall be accounted and used to settle the electricity consumed by him in the future billing periods, as per the procedures specified in sub-regulation (4)

(6) If the electricity generated and injected into the system by the eligible consumer as measured in the solar meter, is less than the total electricity consumed in all the premises owned by him within the area of supply of the licensee, during any billing period, the licensee shall recover from such eligible consumer, the electricity charges at the rates specified in tariff order issued by the Commission, for the net quantum of electricity consumed by him from the distribution system, after taking into account any electricity credit balance remaining from previous billing periods.

(7) The licensee shall give a statement of accounts of electricity showing the following particulars, along with the energy bill relating to each billing period:

- (i) quantum of electricity injected into the distribution system by the eligible consumer;
- (ii) quantum of electricity supplied by distribution licensee to the eligible consumer;
- (iii) quantum of net electricity which has been billed for payment by the consumer;
- (iv) quantum of electricity generated and injected into the distribution system in excess of the consumption by the eligible consumer which is carried over to the next billing period:

(8) The licensee shall pay for the net excess electricity injected into the distribution system from the solar energy system of an eligible consumer at the end of the settlement period at the average pooled purchase cost of electricity for the year.

17. Solar Renewable Purchase Obligation.- (1) The quantum of electricity generated from the solar energy system of an eligible consumer and consumed by him, shall qualify for accounting towards the Renewable Purchase Obligation (RPO) of such eligible consumer if he is an obligated entity under Kerala State Electricity Regulatory Commission (Renewable Purchase Obligation and its Compliance) Regulation, 2010.

(2) The quantum of electricity generated from the solar energy system of an eligible consumer, shall qualify for accounting towards the Renewable Purchase Obligation (RPO) of the distribution licensee if the eligible consumer is not an obligated entity

under Kerala State Electricity Regulatory Commission (Renewable Purchase Obligation and its Compliance) Regulation, 2010.

18. Exemption from banking charge and cross subsidy surcharge.- The electricity generated by an eligible consumer using the solar energy system installed in his premises, whether owned by him or by a third party, shall be exempted from banking charge and cross subsidy surcharge.

19. Power to give directions.- The Commission may from time to time issue such directions and orders as are considered appropriate for the implementation of these Regulations.

20. Power to relax.- The Commission may, by general or special order, for reasons to be recorded in writing, and after giving to the concerned parties likely to be affected, an opportunity of being heard, relax any of the provisions of these Regulations on its own motion or on an application made before it by any person.

21. Power to amend.- The Commission may from time to time add, vary, alter, suspend, modify, amend or repeal any of the provisions of these Regulations.

Sd/-
Secretary
Kerala State Electricity Regulatory Commission

ANNEXURE - 1

GRID INTERACTIVE SOLAR ENERGY SYSTEM

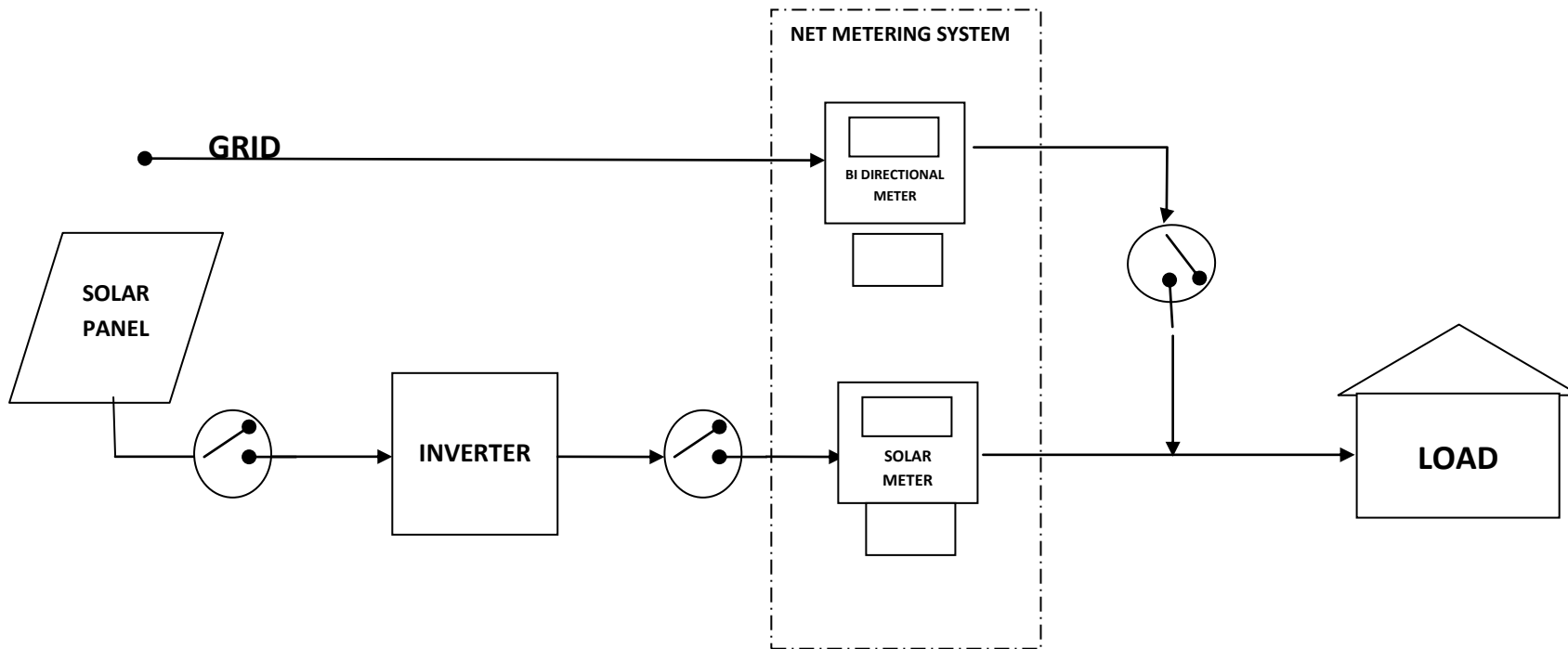

Application form for Net Metering Connection

To

The Section Officer / Designated Officer
Distribution Licensee
(Name of Office)

Date: (date)

I/We herewith apply for a solar energy net-metering connection at the service connection and for the solar PV plant of which details are given below.

1	Name of Consumer	
2	Address of the premises where solar energy system is proposed to be installed	
3	Consumer No. and Category of Consumer	
4	Connected load / contracted load of the consumer	
5	Capacity of solar energy system proposed to be installed	
6	Whether consumer proposes to purchase solar meter and net metering system	
7	Solar grid inverter make and type	
8	Solar grid inverter has automatic isolation protection (Y/N)	
9	Telephone No.	
10	Expected date of commissioning of solar PV system	

Proof of ownership and proof of address as specified in Kerala Supply Code 2014 shall also be submitted along with application form.

Name:

Signature:

Acknowledgement of Application for Net-Metering

Received an application for a solar energy net-metering connection from,

Name :

Date :

Consumer No. :

Application Registration No. :

Solar Plant Capacity :

Name of Officer :

Signature :

Designation